



MELISSA WOO    ERIC DENNA  
-----  
CIO OREGON    CIO UTAH

KLARA JELINKOVA    SHEL WAGGENER  
CIO U OF CHICAGO    SVP INTERNET2



## **RUCC: Trust and Identity**

# **Critical Infrastructure for Research and Education in the Coming Decade**

# A Short History: Identity Management 1960-2012

In the beginning, there were individual accounts for individual systems – the “Mainframe Model”

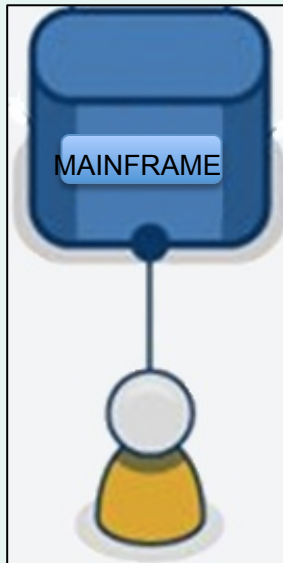

Client Server then Intranet broke that. So we invented “Single Sign-On”

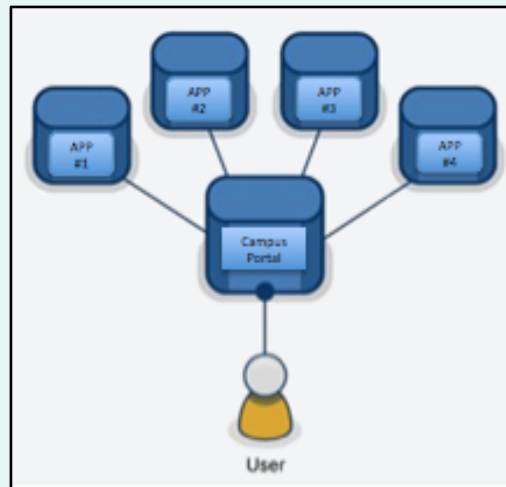

Then Federation was established to apply SSO across multiple campuses

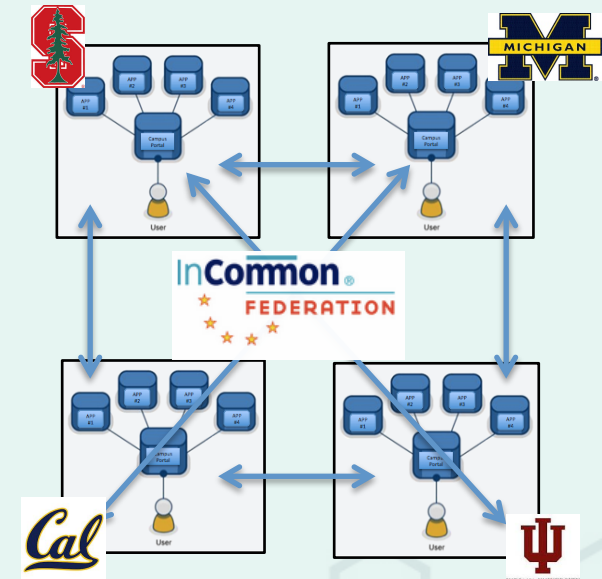

# What did all of these have in common? Enterprise Design as the Core

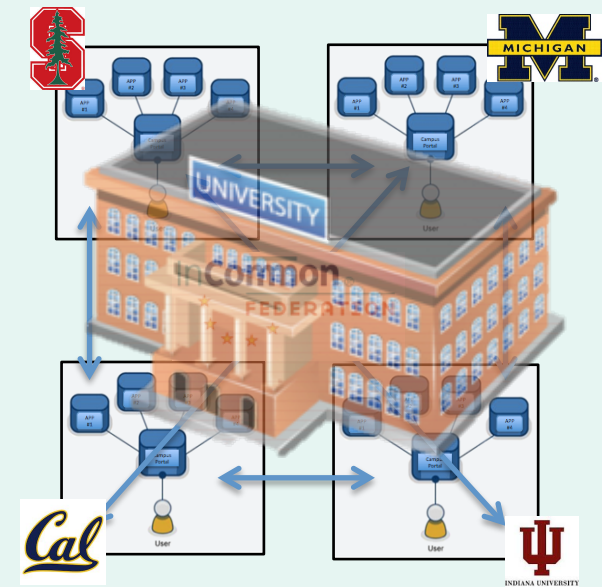
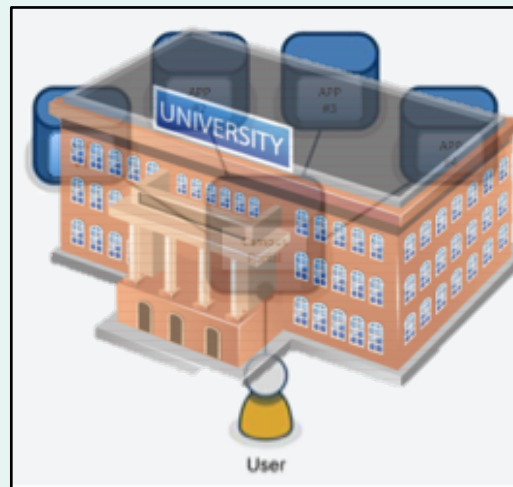
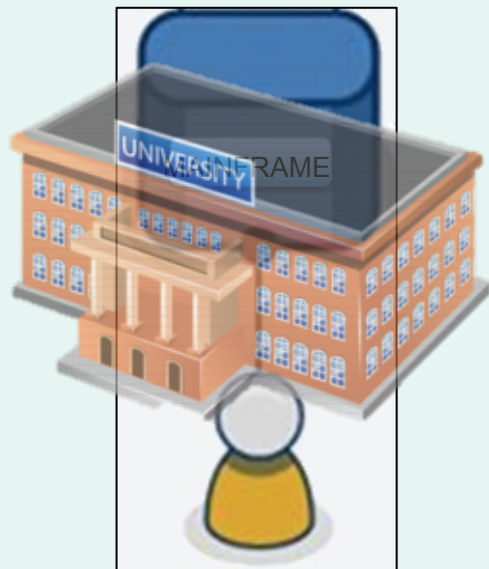

# Where does the core offer the greatest leverage and design advantage? The Individual!

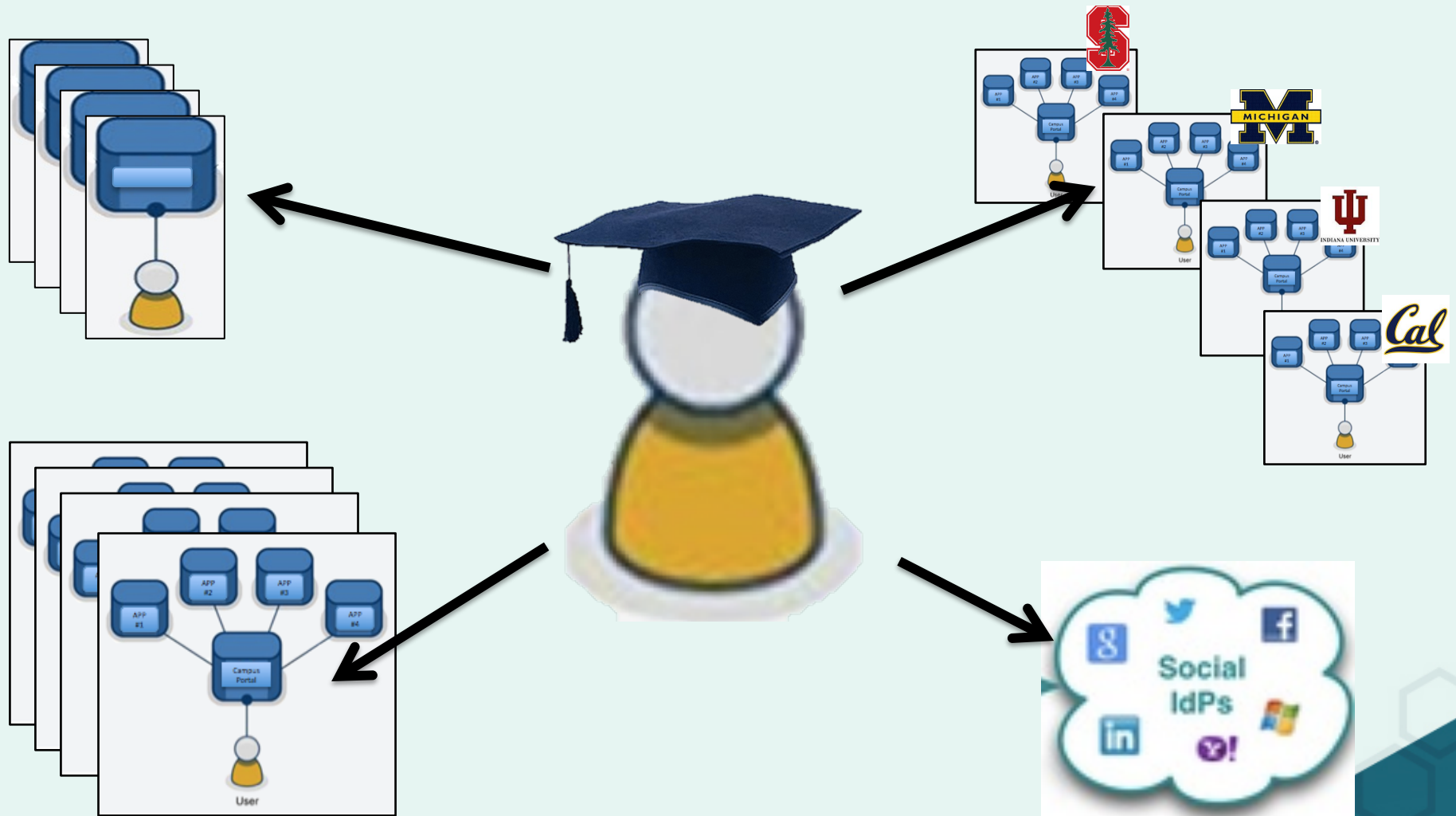

# A Needed Future: Trust and Identity 2014-2024

Empower “Individual Opt In” and Require Standards plus “Commitment of Participation” for Release of key Institutional Attributes

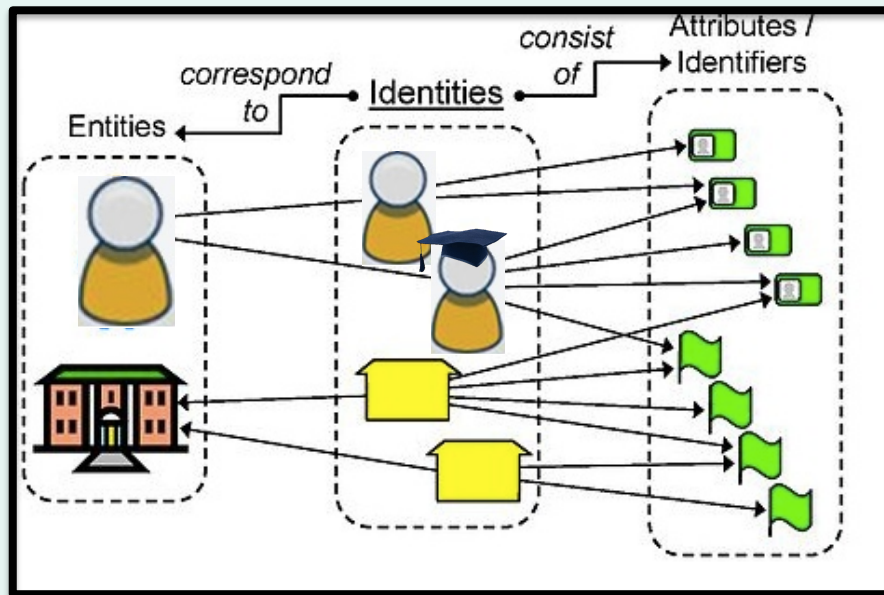

Adjusted Design Point for all Trust and Identity Activities from “Enterprise” To “Virtual Organization

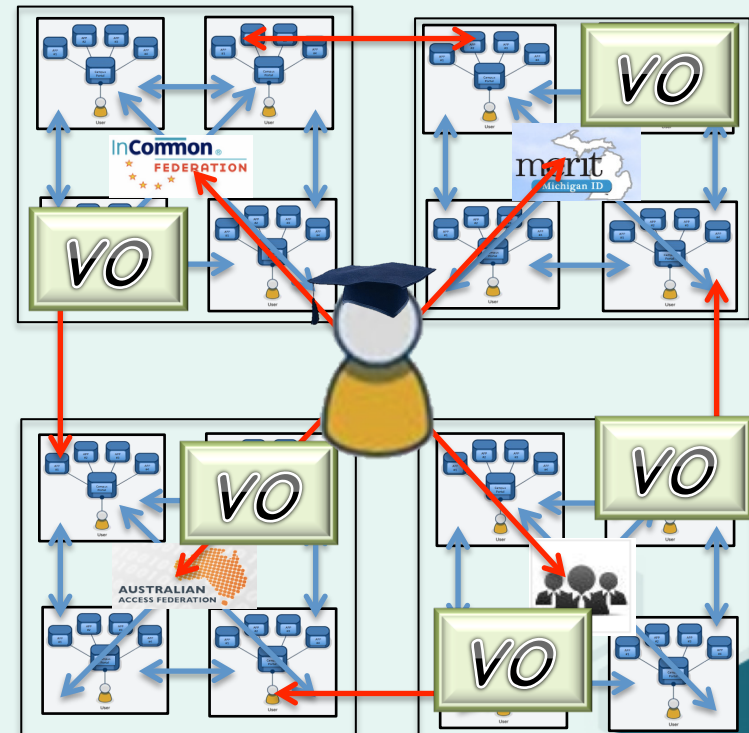

# A Needed Future: Trust and Identity 2014-2024

Aligned Comprehensive Governance (and Strategy) for all higher education middleware and services by **TIER**

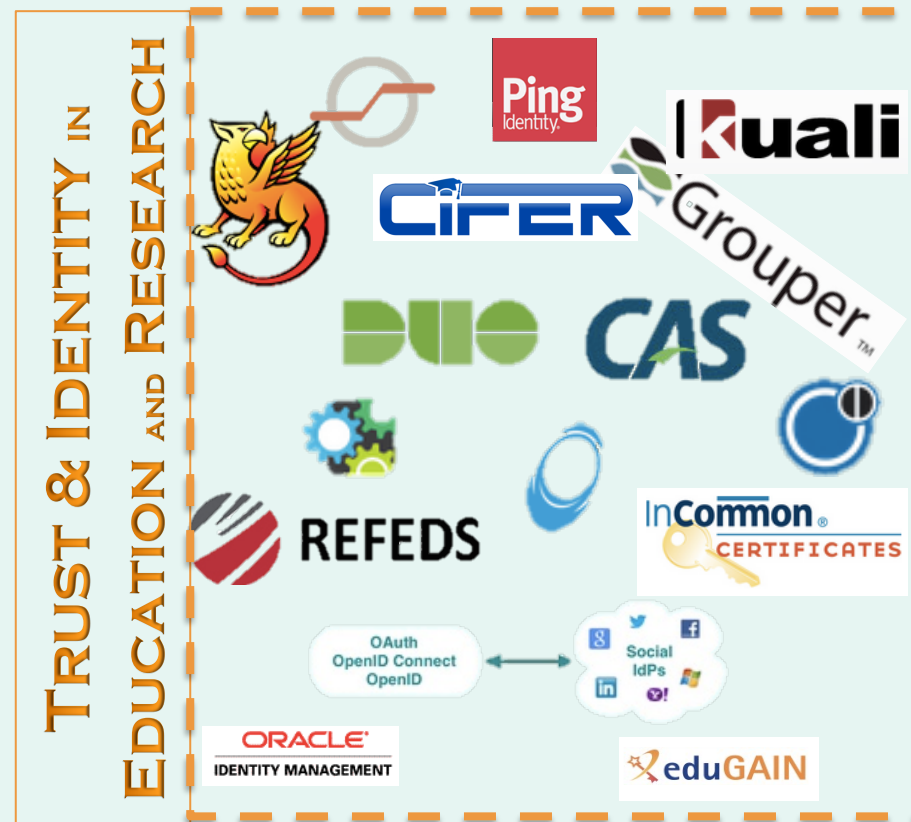

## Four Parallel Work Streams to Deliver TIER

### TRUST & IDENTITY IN EDUCATION AND RESEARCH

#### Governance

The Trust and Identity governance will have responsibility for the larger higher education community and incorporate all community offerings and architectural standard decisions. Klara J. Chair.

#### Architecture

All architecture for middleware, API and service integration for trust and identity will be mapped and coordinated through here for review and approval by the steering committee. Steve Zoppi Lead

#### Campus

Campus to work internally to implement adoption of standards as identified above, with specific requirements for participation in an updated federation structure around attributes. Campus CIO's Lead

#### Develop and Deploy

All products will be adopted based on above architecture, with objective to develop an integrate suite ultimately leading to Identity as a Service. Some individual projects needed here. S. Zoppi Lead

# DISCUSSION